

Abgasprüfstelle (AFHB)
Contrôle des gaz d'échappement
Gwerdtstrasse 5
CH-2560 Nidau
Tel./Tél. +41 (0)32 321 66 80
Fax +41 (0)32 321 66 81

VERT Filter Test, Phase 1 with the Diesel Particle Filter LiqTech SiC 150 cpsi on the Liebherr D 934 S Engine

according to the VERT ^{*)} measuring procedure (VFT 1)

Ordered by:

LiqTech A/S, Grusbakken 12, DK 2820 Gentofte, Danmark

Projekt leading:

TTM, Technik Thermische Maschinen, Niederrohrdorf / Schweiz

Report:

J. Czerwinski, Dipl. Ing. Dr. techn.,
Th. Hilfiker, Dipl. Ing. FH
T. Neubert, Dipl. Ing. FH
University of Appl. Sciences, Biel-Bienne
LAB. FOR EXHAUST EMISSION CONTROL
Gwerdtstrasse 5, CH-2560 Nidau / Switzerland

M. Kasper, Dr. sc. nat. ETH
Th. Mosimann, Dipl. Ing. HTL
A. Hess, MSc. ETH
Matter Engineering AG, 5610 Wohlen

CONTENTS

1.	SUMMARY	3
2.	INTRODUCTION	3
3.	LEGAL BACKGROUND and VFT-OBJECTIVES	4
4.	VFT TEST-PROTOCOL	5
	4.1. Test-cycle and procedure	5
	4.2. Sampling lines and test-arrangement	7
5.	AVAILABLE INFORMATION	8
	5.1. General information on emission with traps and fuel-additives	8
	5.2. General information on secondary gaseous emissions with traps and fuel-additives	9
	5.3. Increase of NO ₂ /NO ratio when using noble metal coatings	10
	5.4. Results with the same DPF material	10
6.	PARTICIPATING LABORATORIES and RESPONSIBLE PERSONS	11
7.	TEST-ENGINE, FUEL and LUBRICANT	11
	7.1. Test engine data	11
	7.2. Fuel data	12
	7.3. Lubricating oil data	12
8.	TEST METHODS and INSTRUMENTATION	13
	8.1. Engine dynamometer and standard test equipment	13
	8.2. Test equipment for regulated exhaust gas emissions	14
	8.3. Particle Size Analysis and optional analytical methods	15
9.	TEST ROUTINE	15
10.	TEST OBJECTS	16
	10.1. Particle filter	16
11.	RESULTS	17
12.	CONCLUSIONS	18
13.	DOCUMENTATION	18
14.	LITERATURE	18
15.	LIST OF ATTACHED FIGURES	20
16.	APPENDICES	21

1. SUMMARY

This report summarizes the investigations with the Diesel Particle Filter LiqTech SiC 150 cpsi on a Liebherr construction engine according to the VERT^{*)} Filter Test Phase 1.

The investigations comprise all measurements and evaluations, which were performed on construction site engines within the scope of the VERT^{*)} project. The size distributions of the particulates were systematically measured besides the usual engine operating parameters, volatile pollution emissions and particulate mass emissions.

The analysis was performed at four operating points of the engine and during the attempt of charging and regeneration of the DPF by means of catalytic additive (FBC) and of increased engine load.

The results can be summarized as follows:

- with the investigated DPF there is a very efficient filtration of nanoparticulates (up to 99.96 %)
- the used DPF eliminates very well the opacimetric acceleration smoke
- the regeneration of the DPF with the catalytic additive worked very well
- due to the application of FBC there is no increase of NO₂ – in contrary reduction of NO₂ and of HC takes place.

Regarding the filtration efficiency the investigated DPF fulfils the criteria of the VERT filter test phase 1.

2. INTRODUCTION

The occupational health authorities of Switzerland, Austria and Germany: SUVA, AUVA and TBG together with the Swiss clean air authority BAFU have performed the VERT project 1994-1999 to satisfy the increasingly stringent demands on air quality in underground workplaces and offroad [1].

Targets of VERT

- Evaluate aftertreatment systems for existing engines to reduce particulate emissions to < 5 % of engine-out emissions levels - with respect to total EC+OC-mass and particle number count in the size range 10-500 nm
- Define certification procedures for such aftertreatment systems
- Establish rules for monitoring field emissions of offroad engines
- Define application guidelines in consensus with engine manufacturers and operators.

VERT was concluded 3/2000 [2] with application tools such as trap-system-specification, certification procedures and field monitoring standards and a list of VERT-approved trap-systems published in the SUVA/BAFU-Filter-List [3], yearly updated. Only traps systems which have successfully passed the VERT-Filter-Test VFT will be listed in this document and they will only remain in this list if they continue to prove their quality in the field.

*) VERT... Verminderung der Emissionen von Realmaschinen im Tunnelbau
Verification Emission Reduction Traps

The particulate trap system has proved to be the only available effective measure to curtail particulate emissions. Regeneration of such traps requires appropriate technical means such as burners, heaters, catalytic coatings or fuel additives. All such means must be certified together with the trap system and quality-monitored in the field. Continuous electronic OBD is a further requirement to control such systems, which need to perform automatically and safe for the engines and the environment.

Research on trap systems has revealed that traps can become highly active chemical reactors because of their extremely high specific surface. They can adsorb any substances offered by the exhaust gas, extend their residence time under high temperature conditions and thereby create products which did not exist in the exhaust before or in much lower concentrations. This chemical activity can be increased by the presence of catalysts originating from fuel or lube-oil, additives or coatings. It has been shown that extremely toxic substances can be created such as PCDD/F^{**}) in very high concentrations [4]. This has prompted the introduction of a so-called VERT-Secondary-Emission-Test VSET which must be performed in all cases where such catalytic means are used.

Swiss legislation for the workplace [5] and offroad [6] where traps are now mandatory on all Diesel engines is based on VERT-results and requires exclusive use of systems which have successfully passed VFT and VSET. These test protocols are also approved by the German UBA, the Austrian AUVA, the German TBG and the Canadian DEEP.

The VERT measuring procedures were carefully reconsidered and described in the Swiss Norm SNR 277205 (Sept. 2007), [7].

3. LEGAL BACKGROUND and VFT-OBJECTIVES

Swiss legislation supports the use of particulate traps but in case of regeneration procedures using fuel additives or catalytic coatings it requires to proof that there will be no additional substances produced which can affect human health or the environment in general.

The first regulation issued by the EJPD (Swiss Ministry of Justice) on 7. August 1990, based on Art. 84 Abs.1 BAV states " In Verkehr stehende und neue, ohne Partikelfilter typengeprüfte Fahrzeuge, können nachträglich mit Partikelfiltern ausgerüstet werden.....beim Einsatz von additiv- oder katalytischunterstützten Regenerationsverfahren ist nachzuweisen, dass eine Gefährdung von Gesundheit und Umwelt durch die zusätzlichen entstehenden Reaktionsprodukte ausgeschlossen ist" [8].

Based on this the VERT trap-system specification requires under "additional constrains for emissions", that "there shall be no clearly detectable and relevant increase of the following emissions compared to the initial engine conditions" – even during regeneration:

- CO, HC, NO, NO₂ (mandatory)
- sulphuric acid and/or sulfate formation (desirable)
- solid particles of any substance in the size range 10-500 nm (mandatory)
- secondary emissions such as dioxins/ furans and PAH (mandatory)

where "relevant" is defined by the SUVA MAK-threshold levels at the working place and the general BAFU (Swiss EPA) threshold levels for ambient air [7, 9].

VFT-Objectives:

Objectives of the three phases of the VERT-Filter-Test are:

^{**}) PCDD/F... polychlorinated dibenzodioxins / furans (isomers)

Phase 1 (engine dynamometer tests):

- quality control of the filter material – filtration efficiency of counts and of mass at different soot loading
- functionality of regeneration system
- particle size analysis over 10-500 nm:
no particle number concentrations above engine-out particle number concentration level are permitted in any size range.
overall filtration efficiency for additive ash particles must be at least as good as for soot particles
- monitoring of gaseous emissions during regenerations (part of VFT):
no peaks of CO, HC or PM are permitted which increase the overall test-cycle emissions without regeneration by more than 1 standard deviation.

Phase 2 (field test):

- control of the long-term behaviour of the particulate trap system in field application

Phase 3 (engine dynamometer tests):

- shortened procedure of the trap quality control after a long field application (until 2000 h)

Beside of these requirements particulate trap-systems installed and operating in offroad vehicles must comply with existing legislation in particular with respect to noise emission, safety aspects [10] and new-substance-regulations, [11].

4. VFT TEST-PROTOCOL

4.1. Test-Cycle and procedure (on engine dynamometer)

In general 4 operating points of the ISO-cycle 8178 C/4 C1 designed for construction site engines have been selected as the basis for all emission measurements, **Fig. 1** (symbols x):

- Operating point 5: full load, rated RPM
- Operating point 7: full load, mean RPM (max. torque)
- Operating point 3: rated RPM, 50% load
- Operating point 1: mean RPM, 50% load

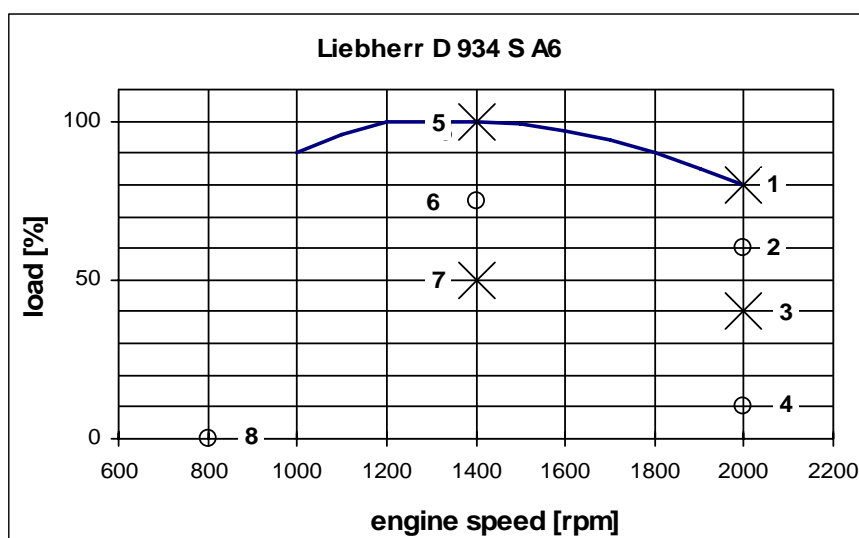

Fig. 1: Operating points of the VERT-Filter-Test

The test is driven in the fixed sequence after a warm-up phase until engine coolant temperature reached $>83\text{ }^{\circ}\text{C}$ and lube-oil $>90^{\circ}$ (test routine see chap. 9).

VFT, Phase 1

The first quality control of the trap is the free acceleration with opacity measurement. The peak opacity has to be lower than 5%.

The following test sequences are:

- 4-point-test with a “trap new” (or in state of delivery), free acceleration smoke
- charging of the trap with soot
- 2-point-test with a “trap soot-loaded”, free acceleration smoke
- regeneration of the trap with additive
- 4-point-test with a “trap regenerated”, free acceleration smoke.

According to the VERT-experiences the opacimetry at free acceleration furnishes the same informations, as at torque-converter acceleration.

During the regeneration test the engine torque is increased at nominal (constant) speed. While the exhaust gas temperature increases the regeneration is indicated by means of the back-pressure, exhaust gas emissions and NanoMet-signals. All those parameters are on-line measured, [Fig. 2](#).

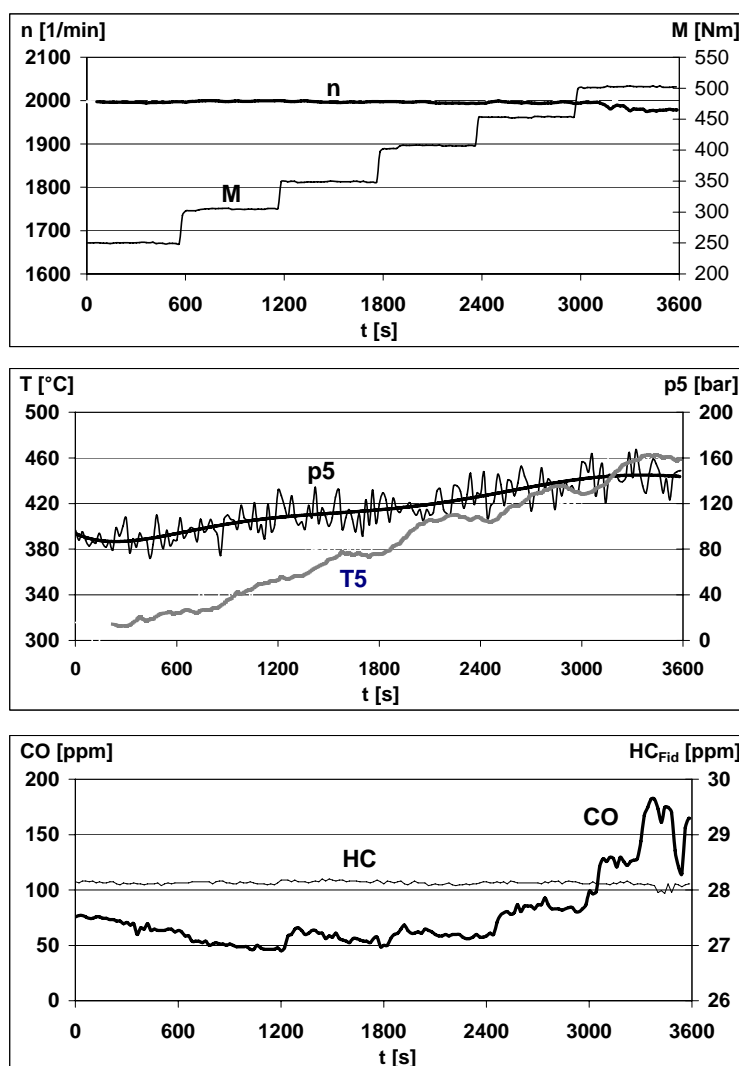

Fig. 2: Regeneration of a trap with an Fe-additive, [15] (on engine dynamometer).

In certain cases, e.g. if the filter material was already measured in another type of trap, a shortened test procedure of the VFT, phase 1 can be applied.

The performed measurements in this case are, [12]:

- free accelerations
- loading of the trap
- regeneration of the trap with additive
- 4-points test procedure with the trap “regenerated”
- free accelerations

4.2. Sampling lines and test-arrangement (on engine dynamometer)

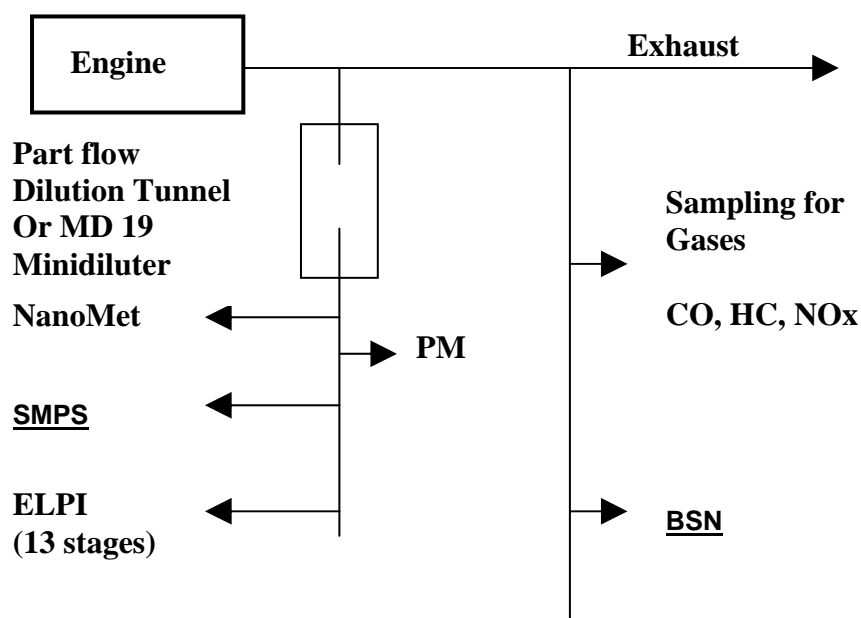

Fig. 3: Principal sketch of the sampling lines and test arrangement

2 sampling lines are used:

- sampling via Part-Flow-Dilution tunnel for direct on-line size, count, and surface information using SMPS, NanoMet and ev. ELPI, as well as for gravimetric particulate mass (PM) measurement
- sampling of gas from the undiluted exhaust gas for the gaseous components and Bosch Smoke Number (BSN)

On-line measurements (for each operating point)

- Regulated pollutants total HC by FID , CO by NDIR, NOx by chemiluminescence detection (CLD)
- Particle count by SMPS in combination with thermodenuder
- Size-specific particulate mass by ELPI (if desired)
- Particle surface and particle composition by NanoMet
- Control parameters: pressures and temperatures.

For details of the sampling, and analysis of nanoparticles see [annex A1](#) and for the off-line optional analytical methods see [annex A2](#).

5. AVAILABLE INFORMATION

5.1. General information on emission with traps and fuel-additives

During the VERT project, experience was obtained regarding the properties of ultrafine particulates at engine-out conditions as well as downstream of the aftertreatment devices such as particulate traps or oxidation catalysts or combinations of both [1], [2], [16], [17], [18], [19].

In particular, it was found that fuel additives (called regeneration additives) mostly reduce particulate mass but increase the number count of ultrafine particles in some cases by two orders of magnitudes forming a clearly pronounced bimodal size distribution of engine-out solid particles. It was proved in previous cases that these were solid non-carbonaceous particles presumably consisting of clusters of primary metal-oxide particles in the size range around 20 nm.

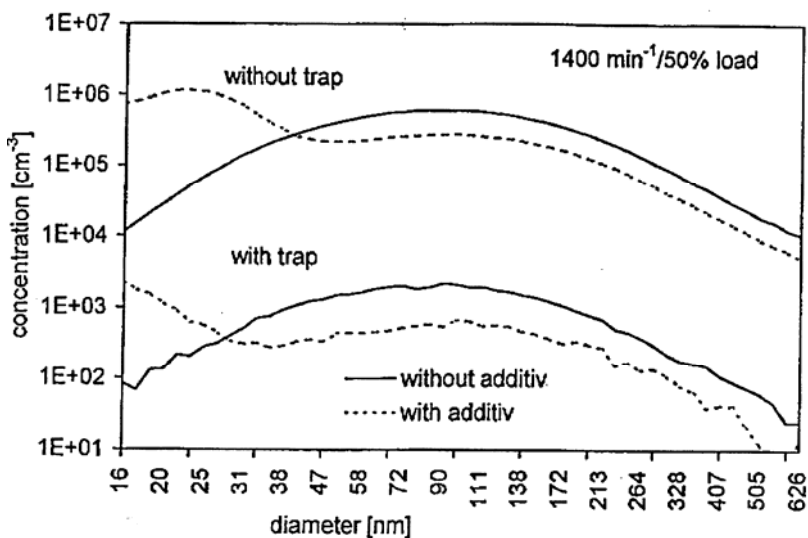

Fig.4: Particle size distribution with/without Additive, [1]

It was also shown that this bimodal distribution was dependent on the additive concentration in the fuel, very pronounced with high concentrations and nearly disappearing with lower concentrations where the additive was still equally active catalysing soot combustion. [13].

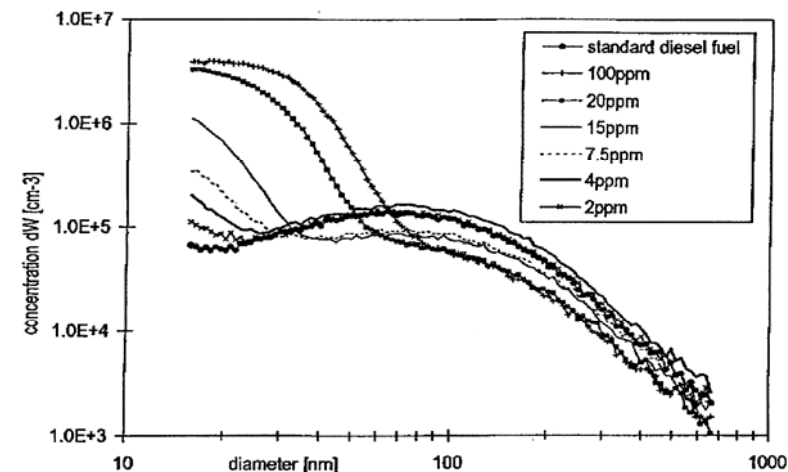

Fig. 5: Additive ash particle formation depending on concentration [13]

In certain configurations, e.g. with particulate traps but without fuel additive, the ultrafine particulate count is increased, too. This is mainly caused by the spontaneous condensation of volatile sulfate or HC. These particulates are mainly fluid and can be absorbed in the activated carbon trap. They are referred to as spontaneous condensate. They particularly occur under conditions where there is little condensation surface of solid particulates available and the pertinent substance is in a saturated state.

When a fuel additive is used with a particulate trap, the count of ultrafine particulates can increase due to a combination of both effects mentioned above.

Experience shows that the particulate traps have a very good filtration rate for carbon particulates.

5.2 General Information on secondary gaseous emissions with traps and fuel-additives

Since traps provide an ideal environment for generation of new substances from the many educts supplied by fuel, lube-oil, combustion and engine wear it must be expected, that such chemical processes can be accelerated by catalysis if catalytically active materials are also present. Fuel additive substances are by definition catalytically active. Two examples from earlier VSET's demonstrate how strong such effects may be thus supporting the need of this kind of test:

Generation of PCDD/F when using a Copper-Additive

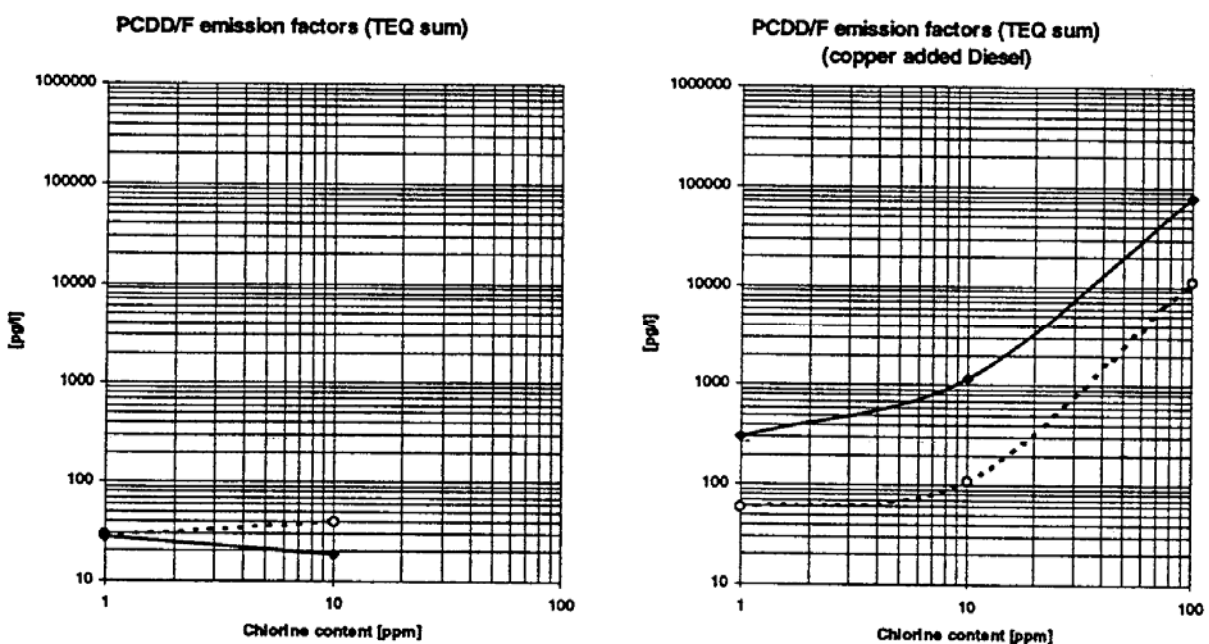

Fig. 6: Left Diagram: with trap (full line) and with fuel additives based on iron and cerium
 Right Diagram: with/without trap and with fuel additive based on copper [4].

When using the copper additive the trap immediately became active, increasing the PCDD/F-emission by about one order of magnitude at limited chlorine content but by more than 3 orders of magnitude for increased chlorine whereas in the case of the Fe- and Ce-additives the PCDD/F-concentration was even reduced with the trap-system.

5.3. Increase of NO₂/NO-ratio when using noble metal coatings

The ratio of NO₂/NO where NO is the less toxic component of NO_x, is usually < 0,1 at engine-out conditions. When using noble metal coatings on high specific-surface substrates however NO can be oxidized to NO₂ which is 6 times more toxic based on MAK-threshold values.

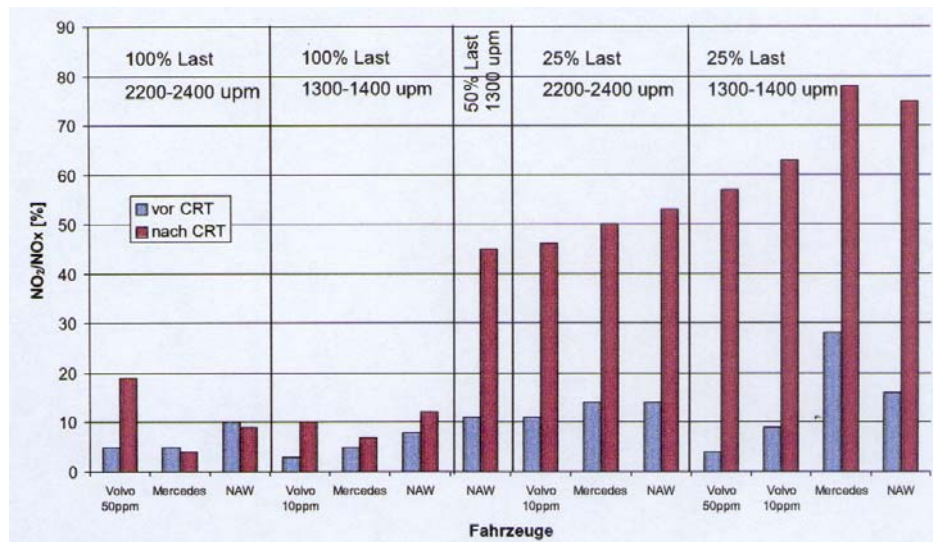

Fig. 7: NO₂/NO_x for 4 city-buses using Pt-coated catalyst in combination with traps [13]

In this case the conversion of NO to NO₂ is performed on purpose to support a soot oxidation process at very low temperatures. This process however is obviously not very well controlled, resulting in high NO₂-slip levels. The same could happen with Pt-containing additives.

It was remarked during several investigations, that the fuel additives (FBC) and some special filter coatings don't produce the higher NO₂-level. More systematic clarifications of these effects were started in 2003.

5.4. Results with the same DPF material

Several DPF's with SiC as filtration material were investigated in the VERT verification procedure.

The SiC monoliths with appropriate pore size showed always a very good filtration efficiency of solid nanoparticles (up to 99,99 % count filtration efficiency) and a total elimination of the acceleration smoke. In [26], the count filtration efficiency up to 99,999 % was measured.

With the state of knowledge of today it is proven, that the effects of condensation, especially sulphates, overlap the gravimetric results and simulate a worse PM-filtration efficiency. In this situation the most useful parameter to qualify the trap is the particle count filtration efficiency.

Due to these effects lower particle mass filtration efficiencies are usually indicated.

6. PARTICIPATING INSTITUTIONS and RESPONSIBLE PERSONS

The following institutions participated in the measurements:

- Laboratories for Exhaust Emission Control of the University of Applied Sciences, Biel-Bienne, CH (Measurements on engine test rig, leading the test program);
Prof. Dr. Jan Czerwinski, Dipl. Ing. T. Neubert.
- Matter Engineering AG / Wohlen, CH (Particle analysis)
Dr. M. Kasper, Dipl. Ing. Th. Mosimann, MSc ETH A. Hess
- TTM Technik Thermische Maschinen, Niederrohrdorf, CH (Project management);
Dipl. Ing. A. Mayer.

7. TEST-ENGINE, FUEL and LUBRICANT

7.1. Test engine data

SNR 277205, Tab. D.3

Manufacturer / type	Liebherr Machines Bulle S.A./ D 934 S
Maximum emission level (legal exhaust level)	97/68/E9 step 3A; EPA/CARB Tier 3
Cylinder number and configuration	4 cylinders in-line
Bore / stroke	136 x 122 [mm]
overall displacement	6.36 [dm ³]
Compression ratio	17 [-]
Serial number / year of manufacture / operating hours	2005 03 1341
Cooling medium (air, water, etc.)	water
Combustion process (direct injection, prechamber, etc.)	direct injection
Fuel system type	unit pump Bosch
Speed governor	EDC
Method of air aspiration	turbocharging
Charge air cooling system	intercooler
Measures to reduce emissions	internal EGR
Rated power / Rated speed (presend EDC setting)	111[kW] @ 2000 [min ⁻¹]
Low idle speed / high idle speed	840 [min ⁻¹]; 2170 [min ⁻¹]

Test points of motor in accordance with ISO 8178-4, test cycle C1				
	Rated speed		Intermediate speed	
Test phase	1	3	5	7
Speed [min ⁻¹]	2000	2000	1400	1400
Torque [Nm]	500	250	680	340
Power [kW]	104.7	52.3	99.6	49.8

7.2. Fuel data according to SN EN 590

SNR 277205, Tab. D.4

Base fuel (without additive)			
Type	Diesel fuel Swiss market quality		
Manufacturer	Shell Formula		
Property	Method	Unit	
Density (at 15°C)	ISO 3675	kg/l	0.820 – 0.845
Viscosity (at 40°C)	ISO 3104	mm ² /s	2.2 – 2.8
Cetane number	ISO 5165	-	52 - 54
Cetane index	ISO 4264	-	49 - 51
Sulphur content	ISO 4260 / 8754	mg / kg	max. 10
Cloud point	ISO 3015	°C	max. -10
Pour point (CFPP)	ISO 3016	°C	max. -20
Flash point	ISO 2719	°C	min 62
Heating value		MJ/kg	min 42.5
Aromatic hydrocarbons	ISO 3837	% vol	max. 2
Conradson at 10% test residue			max. 0.02 g/100g
Boiling analysis (at 1013 mbar, 340°C)			min. 98 vol%

7.3. Lubricating oil data

Lubrizol research oil OS No. 165108, blue, 15W/40

Property		
Viscosity kin 40°C	-	mm ² /s
Viscosity kin 100°C	13.98	mm ² /s
Viscosity index	-	(--)
Density 20°C	-	kg/m ³
Pourpoint	- 25	°C
Flamepoint	-	°C
Total Base Number TBN	8.4	mg KOH/g
Sulfur ashes	10 770	mg/kg
Sulfur	3 360	mg/kg
Mg	< 10	mg/kg
Zn	1 200	mg/kg
Ca	2 630	mg/kg
P	1 110	mg/kg

8. TEST METHODS AND INSTRUMENTATION

8.1. Engine dynamometer and standard test equipment

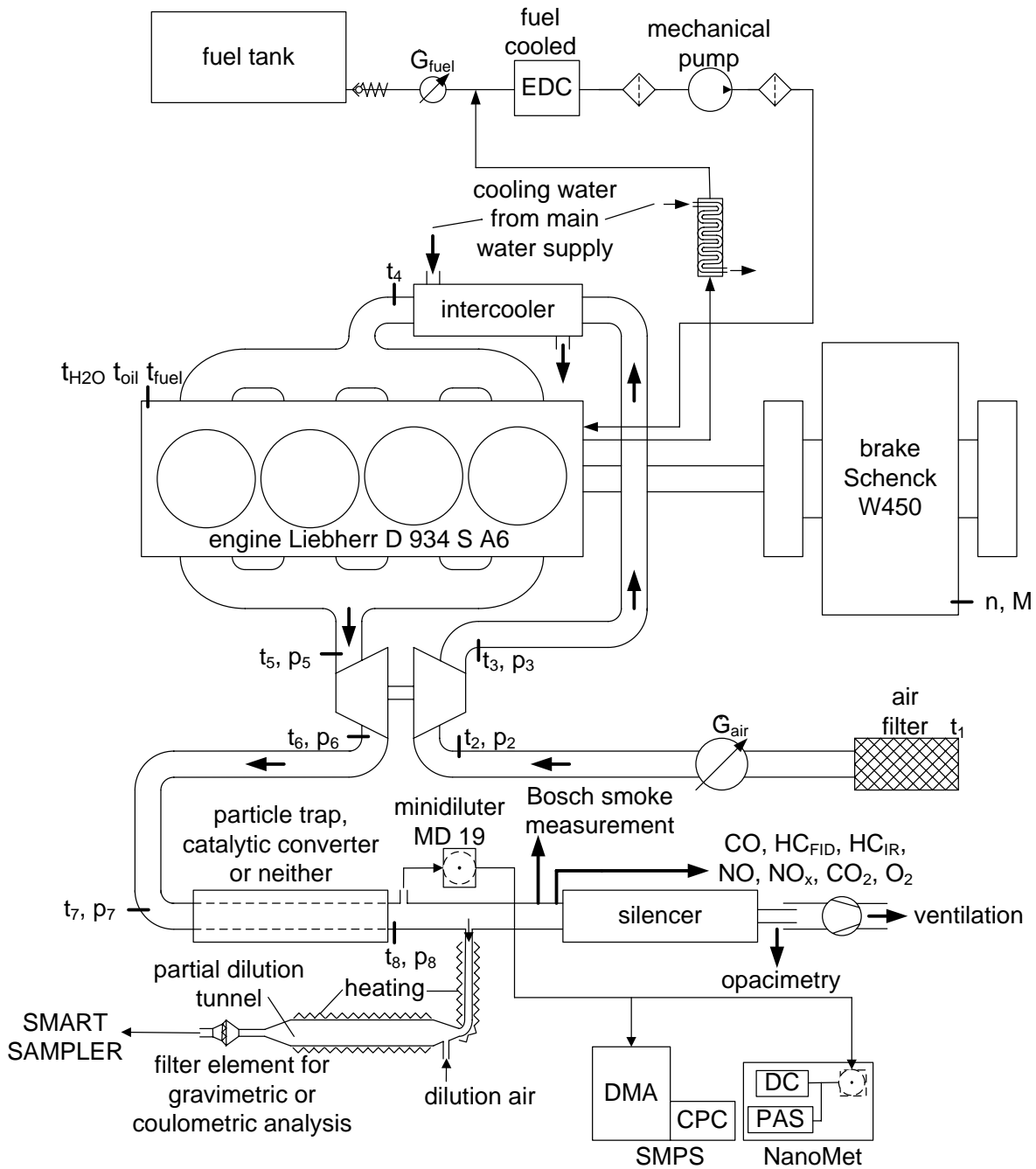

Fig. 8: Engine dynamometer and standard test equipment

Following laboratory equipment was employed:

- Eddy current brake Schenk W450 with force transducer HBM U2
- Fuel flow measurement AIC 2022 with through-flow meter FS-4/2400
- Air mass meter Degussa Deguflow 8740-20600
- Pressure transducers Keller KAA-2/8235, PD-4/8236
- Thermo-couples Type J,K
- Air filter Durulator P77-1558 (Duramont)
- Intake air conditioning: none (manual)
- Silencer: DINEX

The engine cell and the measuring cell are separated.

Different parameters are registered on-line via PC or on a chart recorder. The continuous registration of all parameters is possible.

8.2. Test equipment for regulated exhaust gas emissions

Measurement is performed according to the swiss exhaust gas emissions regulation for heavy duty vehicles (FAV2 / Oct. 22. 1986 and updates resulting from the technical development):

- Volatile components:
 - Horiba exhaust gas measurement devices
Type VIA-510 for CO₂, CO, HC_{IR}, O₂,
Type: CLA-510 for NO, NO_x
 - Amluk exhaust gas measurement device Type FID 2010 for HC_{FID},
- Measurement of the particulate emission:
 - Sampling and dilution:
partial flow dilution tunnel AVL Smart Sampler II, Model 472
tunnel diameter 70 mm
tunnel length 700 mm
mass flow constant 2 g/s
dilution air, purified, oil-free compressed air, usually 1.6 g/s (dilution 1:5)
dilution factor DF is variable, determined by means of CO_{2L/H}-measurement
 - Gravimetry:
filter material PALFLEX TX 40 HI 20-WW
filter efficiency: 95% (300nm) until 99% (10 nm) (see SAE 950373, own measurements),
filter temperature: ≤ 52 °C
mass of filter residue usually about 1 mg
accuracy of the scale ± 1 µg
conditioning: 8 .. 24 h (20°C, rel. humidity 50%)
 - Opacimetry:
AVL Dismoke 435 (1993)

Calculations are done with the user-software MS Excel 8.0. All data are saved and are available for further evaluations.

The corrected exhaust emissions are calculated according to the Swiss Regulation for Exhaust Emissions from Heavy Duty Vehicles, which responses to the directive 2005 / 55 / ECE & ISO 8178. Formulae used for calculation are listed in appendix A3, nomenclature see A4.

8.3. Particle Size Analysis and optional analytical methods

In addition to the gravimetric measurement of particulate mass, the particle size and counts distributions are analysed with following apparatus:

- SMPS – Scanning Mobility Particle Sizer, TSI (DMA TSI 3071, CPC TSI 3025 A)
- NanoMet – System consisting of:
 - PAS – Photoelectric Aerosol Sensor (Eco Chem PAS 2000)
 - DC – Diffusion Charging Sensor (Matter Eng. LQ1-DC)
 - MD19 tunable minidiluter (Matter Eng. MD19-2E).
 - Thermoconditioner (TC) (i.e. MD19 + postdilution sample heating until 300°C)

A detailed description of those systems can be found in [annex A1](#) and in references [20-25].

The optional analyses, which can be performed in external analytical laboratories (EMPA, SUVA and others) are:

- coulometric analysis of PM-filtrate residue, giving EC & OC,
- analysis of SOF / INSOF and sulfates in PM by solvent methods,
- analysis of PAH in gas phase and in PM.

Some further explanations about these methods see [annex A2](#).

9. TEST ROUTINE

- Engine conditioning: with particulate trap 60 minutes; without particulate trap 40 minutes
- Conditioning program: 5 load points, equal duration, ascending load from idling to full load
- Start of the measurements: 5 min. after setting the operation point
- For size distributions: 30s after setting the operating point
- Time for complete test sequence: 10 min. per operating point
- Time for repetition measurement: 10 min.
- Sequence of operating points: point 5 – 7 – 3 – 1 – 5 rep.
- Particulate gravimetry: after the size distribution analysis (sampling 3 min.)
- Free acceleration with opacimetry

Monitoring of the test conditions

- Ambient temperature: one measurement per test sequence
- Barometric pressure: one measurement per test sequence
- Ambient humidity: one measurement per test sequence
- CO₂ content of the ambient air: one measurement per test sequence
- Temperature in the test cell: not regulated
- Air inlet temperature after the filter: 20°C-25°C, manually controlled by mixing with outside air (except for very high ambient temperatures)
- Oil pressure and oil temperature: continuous monitoring by test rig control
- Engine cooling water temperature: continuous monitoring as per manufacturer specifications

10. TEST OBJECTS

10.1. Particle filter

SNR 277205, Tab. D.1

Manufacturer of filter system	LiqTech A/S
Type / serial number	
Designation of particle filter family	
Filter medium (particle filter element)	
Manufacturer of filter medium	LiqTech A/S
Type	Wall Flow Filter
External dimensions / weight	Diameter 286mm, Length 355mm
Material	100% RE SiC
Porosity	43%
Pore size distribution	12 – 15 microns
No. of cells per square inch [CPSI]	150
Wall thickness	0.5mm
Maximum flow-through rate [m ³ /s]	1600 @ 1013.25mbar and 20°C
Maximum space velocity [s ⁻¹]	16.8 in VFT 21.1 *)
Maximum operating temperature [°C]	Exhaust gas at 700°C
Storage capacity for soot/ash	0.276kg soot and 0.322kg ash

Regeneration	
Regeneration procedure	For the purpose of the VFT1: FBC manually dosed
With additive (FBC = fuel borne catalyst)	
Manufacturer	INNOSPEC
Specification of additive	Satacen 3
Catalytically active substances	Fe
Treat rate	50 ppm metal (for VFT1) (1ml/l)
Additizing procedure	Acc. To INNOSPEC
Specification of dosage device	-
With catalytic coating	-
Catalytically active elements / concentration of catalytically active substances	-
OBC (electronic on board control unit)	
Type / serial number	-

The tested filter Hug mobiclean on the engine stand is represented in [annex A5](#). Technical information from manufacturer – is represented in [annex A6](#).

*) see annex A10 (at bottom)

11. RESULTS

The graphic representation of results is given in the attached figures, see chap. 15.

The results of measurements and calculated parameters are tabulated in annex, A7, A8, A9, A10, see chap. 16.

Following tendencies can be seen:

Fig. 9 - the LiqTech DPF shows a very good reduction of particle mass PM.

Nevertheless one of the most important statements of VERT is: gravimetry is not an appropriate parameter to characterize the DPF quality. The right metric is the nanoparticles count concentration.

There is no catalytic influence of the measured DPF-system on the gaseous emission components. Slight reduction of HC through the filtration and reduction of NO₂ are visible.

Fig. 10 – the investigated DPF eliminates very efficiently the black smoke during the free acceleration, which is particularly demonstrated by the NanoMet signals PAS & DC.

In the following Figures 11 - 15 the SMPS particle size distribution spectra (PSD) without and with DPF in state of delivery “new” are represented.

There is generally a good filtration efficiency with penetration values mostly by 0.001 – 0.01.

For the DPF “charged”, Fig. 16 & 17 and for DPF “regenerated”, Fig. 18 - 22 there are very good filtration efficiencies – penetration values for “charged” and for “regenerated” mostly below 0.001.

Fig. 23 – the integrated numbers of particles in the size spectrum 20-300 nm show differences with/without DPF, which are of nearly 3 orders of magnitude for all operating points.

Fig. 24 – the integration of the particulate counts in partial size spectra confirms the findings: generally a very good filtration efficiency.

Fig. 25 – shows the results with the on-line measuring sensors at all operating points.

The signals of PAS and DC in this figure are converted to the values responding to the undiluted volume concentrations in the exhaust gas.

PAS (photoelectric aerosol sensor) is sensitive to the surface of particulates and to the chemical properties of the surface. It indicates the solid particles.

DC (diffusion charging sensor) measures the total particle surface independent of the chemical properties. It indicates the solids and the condensates.

Additional information about PAS and DC see annex A1.

With DPF the values of both signals are reduced, the penetrations for DPF new are between 0.01 and 0.001.

Penetration is a parameter representing the portion of particulates passing through the DPF, it is a ratio of down – to upstream concentrations.

$$\text{penetration} = 1 - \text{filtration efficiency}$$

The table in Fig. 26 summarizes the filtration efficiencies for mass (PMFE), or counts (PCFE) filtration of the used LiqTech DPF. The average filtration efficiency for counts PCFE = 99.85%, is very good and sufficient for VERT.

Fig. 27 shows the regeneration attempt, which followed at 2000 rpm with the stepwise increased torque. A clear backpressure drop is not visible due to difficulties of soot loading of the trap.

Fig. 28 represents the results at load steps without DPF.

This measuring series were performed to demonstrate other emission components, in particular PAS, DC, NO_x, NO, NO₂ and compare the results with/without DPF.

In Fig. 29 some considerations of the NO₂-changes with / without DPF at load steps are represented. The LiqTech DPF reduces clearly the NO₂-concentration at all operating points.

12. CONCLUSIONS

The results can be summarized as follows:

- with the investigated DPF there is a very efficient filtration of nanoparticulates (up to 99.96 %)
- the used DPF eliminates very well the opacimetric acceleration smoke
- the regeneration of the DPF with the catalytic additive worked very well
- due to the application of FBC there is no increase of NO₂ – in contrary reduction of NO₂ and of HC takes place.

Regarding the filtration efficiency the investigated DPF fulfils the criteria of the VERT filter test phase 1.

13. DOCUMENTATION

The original data are confidential. They are archived at the Exhaust Gas Laboratory of the University of Applied Sciences, Biel.

14. LITERATURE

- [1] VERT Verminderung der Emissionen von Real-Dieselmotoren im Tunnelbau
Ein Verbundprojekt von Suva, AUVA, TBG und BUWAL, Abschlussbericht
TTM, A. Mayer, 29.2.2000
- [2] VERT CDs 1-4
CD 1: Labor Test
CD 2: Tagebücher Feldtest
CD 3: Messungen Feldtest
CD 4: Abschlussbericht
- [3] Filter list
Verified particulate trap systems for Diesel engines
suvaPro, 1. August 1999
- [4] Influence of particulate trap systems on the composition of Diesel engine exhaust gas emissions
N.V. Heeb, EMPA-Bericht 167985

-
- [5] Filter-Obligatorium
Information zur Einführung des Partikelfilter-Obligatoriums
suvaPro Luzern, 24.1.2000
 - [6] Schweizerische Luftreinhalte-Verordnung (LRV)
Stand 3. Februar 1998, SR 814.318.142.1
 - [7] Testing particle filter systems for internal combustion engines. Swiss Norm SNR 277 205,
Sept. 2007
 - [8] Verordnung zur Nachrüstung von Fahrzeugen mit Partikelfiltern
Eidg. Justiz- und Polizeidepartement, 7. August 1990, V. 7.621.3/V. 7.683.4/V. 7.703
 - [9] Grenzwerte am Arbeitsplatz 1994
Suva Luzern, 1903.d - Ausgabe 1994
 - [10] Bundesgesetz über die Sicherheit von technischen Einrichtungen und Geräten (STEG)
18. Juni 1993
 - [11] Verordnung über umweltgefährdende Stoffe (Stoffverordnung, StoV)
9. Juni 1986/1. Januar 1994
 - [12] Ammann Diesel-Partikel-Filter ARF 10 Typ K und Typ B
VFT-Eignungstest Phase
Ingenieurschule Biel, Abgasprüfstelle
J. Czerwinski, S. Napoli, Mai 2000
 - [13] Analysis of the Particulate Emissions on Liebherr - engine with the fuel additives
DPX9 & CDL PP 3100-C / Report 15
Ingenieurschule Biel, Abgasprüfstelle
J. Czerwinski, T. Mosimann, February 1998
 - [14] Emissionsmessungen an mit CRT ausgerüsteten Stadtbussen auf dem Rollenprüfstand
der LARAG AG in Wil, März 2000
EMPA-Bericht, 411'289
 - [15] Partikelfilter für schwere Nutzfahrzeuge, Technische Grundlagen zur Nachrüstung grosser
Fahrzeugflotten, Oktober 2000
 - [16] Untersuchungen am Caterpillar-Motor mit Verbesserungsmassnahmen und
Trenngradanalyse
VERT-Bericht 5
Ingenieurschule Biel, Abgasprüfstelle
J. Czerwinski, D. Gehrig, Juni 1995
 - [17] Gestrickte Strukturen aus Endlosfasern für die Abgasreinigung
A. Mayer et al., MTZ 56 (1995) 2
 - [18] Particulate Traps for Retro-Fitting Construction Site Engines VERT:
Final Measurements and Implementation
A. Mayer et al.,
SAE 1999-01-0116
 - [19] Nachmessung der Partikelfilter aus dem Baumaschinenfeldtest mit eingehender Analyse der
Partikelemissionen.
VERT-Bericht 16
Ingenieurschule Biel, Abgasprüfstelle Nidau
J. Czerwinski, Th. Mosimann, Mai 1998
 - [20] Scanning Electrical Mobility Spectrometer
S.C. Wang, and R.C. Flagan
Aerosol Science and Technology 13 (1990) p. 230-240

-
- [21] Unipolar and Bipolar Diffusion Charging of Ultrafine Aerosol Particles
M. Adachi, Y. Kousaka, and K. Okuyama
J. Aerosol Sci. 16 (1985) p. 109-123
- [22] Evaluation of the Surface Properties of Nanoparticles
A. Keller, M. Fierz, K. Siegmann, and A. Filippov
J. Aerosol Sci. (2000) in print
- [23] Monitoring PAH-Emissions from Combustion Processes by Photoelectric Charging
H. Burtscher, and H.C. Siegmann
Combust. Sci. and Tech. 101, (1994) p. 327-332
- [24] Dynamic Field Measurement of Submicron Particles from Diesel Engines
U. Matter, H.C. Siegmann, and H. Burtscher
Environ. Sci. Techn. 33 (1999) p. 1946-1952
- [25] An Accurate, Continuously Adjustable Dilution System (1:10 to 1:104) for Submicron Aerosols
Ch. Hueglin, L. Scherrer, and H. Burtscher
J. Aerosol Sci. 28/6 (1997) p. 1049-1055
- [26] J. Czerwinski, J.-L. Pétermann, M. Kasper, Th. Mosimann: VERT Filter Test, Phase 3 with the HUSS DPF Type F50 – MKH with burner on the Liebherr D914T engine. Laboratory for Exhaust Emission Control of the University of Applied Sciences, Biel-Bienne, CH, report B131, Apr. 2003.

15. LIST OF ATTACHED FIGURES

Fig. 9 Comparison of the emission parameters

Fig. 10 Opacity with free acceleration

Fig. 11 SMPS-size distributions, 1400 rpm / 680 Nm, new

Fig. 12 SMPS-size distributions, 1400 rpm / 340 Nm, new

Fig. 13 SMPS-size distributions, 2000 rpm / 250 Nm, new

Fig. 14 SMPS-size distributions, 2000 rpm / 500 Nm, new

Fig. 15 SMPS-size distributions, 1400 rpm / 680 Nm, new

Fig. 16 SMPS-size distributions, 1400 rpm / 340 Nm, charged

Fig. 17 SMPS-size distributions, 2000 rpm / 250 Nm, charged

Fig. 18 SMPS-size distributions, 1400 rpm / 680 Nm, regenerated

Fig. 19 SMPS-size distributions, 1400 rpm / 340 Nm, regenerated

Fig. 20 SMPS-size distributions, 2000 rpm / 250 Nm, regenerated

Fig. 21 SMPS-size distributions, 2000 rpm / 500 Nm, regenerated

Fig. 22 SMPS-size distributions, 1400 rpm / 680 Nm, regenerated

Fig. 23 Integrated counts of particles in the size spectrum 20 – 300 nm

Fig. 24 Integrated counts of particles in different size spectra

Fig. 25 NanoMet-data for each operating point

Fig. 26 Comparison of trapping efficiencies

Fig. 27 Regeneration attempt with stepwise increased torque

Fig. 28 Load steps without DPF

Fig. 29 NO₂-changes at load steps

16. APPENDICES

A 1 Particle size analysis

A 2 Optional off-line analytical methods

A 3 Calculation formulae

A 4 Measured and calculated engine data, nomenclature

A 5 DPF LiqTech SiC 150 cpsi on the test bench

A 6 DPF LiqTech SiC 150 cpsi technical drawings from manufacturer

A 7 Tables of measured and calculated values: w/o DPF, ULSD (10 ppm)

A 8 Tables of measured and calculated values: with DPF, ULSD (10 ppm), new

A 9 Tables of measured and calculated values: with DPF, ULSD (10 ppm), charged

A 10 Tables of measured and calculated values: with DPF, ULSD (10 ppm), regenerated